



Quick change tapping chucks **with** length compensation on compression and expansion

Mandrins de taraudage à changement rapide **avec** compensation longitudinale à la compression et traction



Verwendung:

Zur Aufnahme von Schnellwechsel-Einsätzen für Gewindebohrer.

Application:

For the chucking of Quick change taps for threading taps.

Application:

Pour le serrage des inserts de changement rapide pour tarauds.

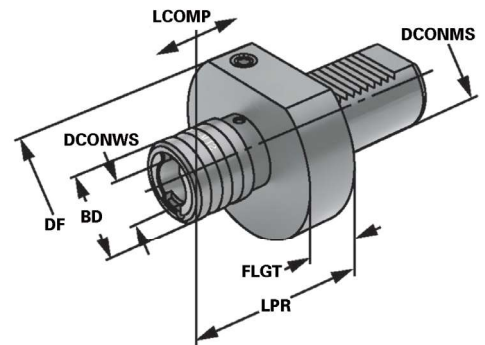

Bestell-Nr. Order no. Référence	DCONMS	Spannbereich Capacity Capacité	SZID	DF	LPR	BD	DCONWS	LCOMP	FLGT
209.16.12	20	M3 – M14	1	50	67	38	19	7	17
259.16.12	25	M3 – M14	1	58	55	38	19	7	18
309.16.12	30	M3 – M14	1	68	58	36	19	7	22
309.16.20	30	M5 – M22	2	68	81	53	31	12	22
409.16.12	40	M3 – M14	1	83	58	36	19	7	22
409.16.20	40	M5 – M22	2	83	81	53	31	12	22
509.16.12	50	M3 – M14	1	98	56	36	19	7	30
509.16.20	50	M5 – M22	2	98	80	53	31	12	30

7



10.42



10.43



10.48

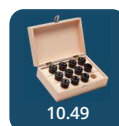

10.49



10.50



7.50

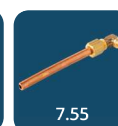

7.55